

DG406 Multiplexer Optimizes Medical Simulator

Gavin Stewart

Introduction

A patient monitoring system collects information from several transducers connected to a patient. The transducers convert physiologic electromechanical activity into electrical signals which are routed to a data acquisition module for digitization. The digitized data is then processed and displayed on the monitor screen. Additionally, bedside patient information can be relayed to a central nursing station, a hospital information system, or a doctor's office.

Patient monitors must provide reliable data at all times. For this reason, it is imperative to have an accurate means for calibration and troubleshooting of patient monitoring instrumentation. This function can be accomplished by using a patient simulator which generates electrical signals similar to those produced by the transducers.

For this application note, a patient simulator was designed and built. The simulator consisted of a personal computer peripheral device and had to be capable of producing the static display of all numerics and graphics associated with the following three human parameters: a) body temperature, b) blood oxygen saturation level, c) heart pulse rate. Having these capabilities greatly enhances the ability to perform fine calibration and troubleshooting.

Performance Goals

The simulator design goals were as follows:

- a) Body temperature: from -1°C to 46°C in 0.1°C increments, with an accuracy of $\pm 0.1^{\circ}\text{C}$.
- b) Blood oxygen saturation level: sixteen independent values in the range of 60% to 100%.
- c) Heart pulse rate: fifteen independent values in the range of 30 to 300 pulses/min.

Theory of Operation

The commands to modify the simulated parameters are sent from a PC over an RS-232 line to the peripheral device. A microcontroller containing a UART receives these commands as 8-bit frames and processes the data. After processing, the microcontroller uses its I/O port bits to send data to the parameter generation hardware. The parameter's signal is modified as specified by the down-loaded command. The modified signals are then output to the patient monitor to produce the appropriate visual displays.

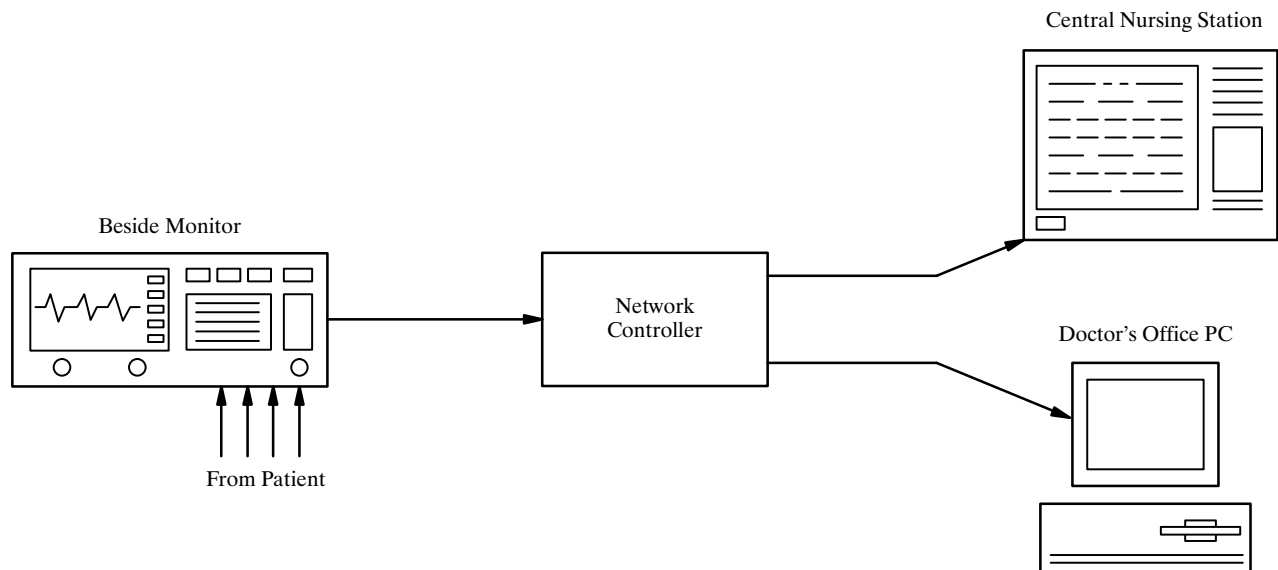

Figure 1. A Typical Medical Information System

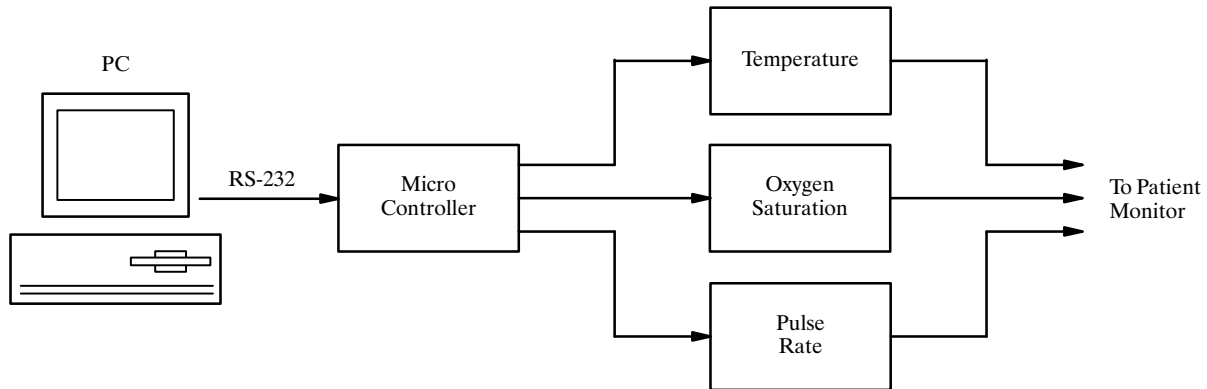

Figure 2. Patient Simulator Block Diagram

Design Considerations

The temperature parameter was simulated by using a discrete resistor array and a pair of analog multiplexers as illustrated in Figure 3. A discrete resistor value representing a known temperature was placed between the same channel of two analog multiplexers. Using its I/O lines, the microcontroller simultaneously selects one of the 16 resistors. A known current is sent through the resistor. The medical monitor reads the voltage drop across the resistor and translates it into a temperature reading.

Since $r_{DS(on)}$ affects the output voltage, in order to obtain accurate results, it was necessary to use the multiplexers with a low on-channel resistance. The temperature simulation section of the design utilized the DG406, a 16-channel multiplexer manufactured by Siliconix. Thus, it

was possible to simulate 16 discrete temperatures by using a pair of multiplexers. The DG406 was ultimately chosen for its low $r_{DS(on)}$ of approximately $40\ \Omega$ typical. This value was measured and confirmed several times. To get the best results possible, lower resistor values were used and a digital potentiometer array was used to get the exact resistance required including the $40\text{-}\Omega$ $r_{DS(on)}$.

Simulating the saturated oxygen level was accomplished utilizing another DG406 multiplexer. An analog signal was sent through the selected channel of the multiplexer and attenuated in a predetermined manner. The resulting signal is then output to the medical patient monitor modifying the saturated oxygen parameter. Again an array of digital pots was used to compensate for the already low on-resistance and to get the exact resistance values desired.

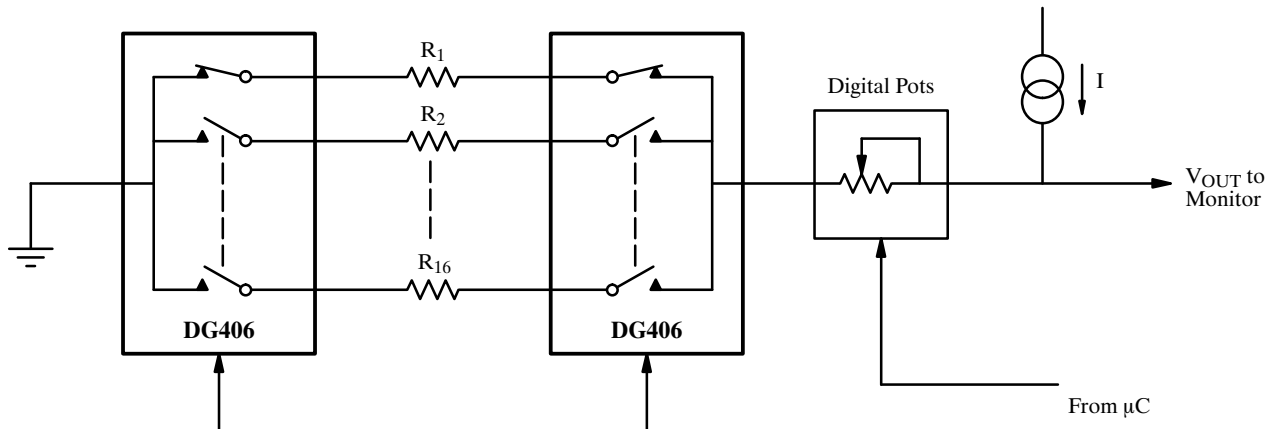

Figure 3. Temperature Simulation Circuit

The pulse rate parameter was simulated by varying the frequency of a square wave obtained from a programmable timer/counter. The timer/counter was programmed using some of the microcontroller I/O lines. The square wave frequency represents the patient's pulse rate.

Conclusion

The finished simulator met all design goals. The DG406 worked as documented in the Siliconix data book. Although this design used lower resistor values and digital pots to

compensate for the $r_{DS(on)}$, this may not be necessary in other less sensitive designs.

The critical components in this design were the microcontroller for its speed and numerous on-board devices, the analog multiplexer for its low $r_{DS(on)}$, and the digital potentiometers. Considerable time was spent shopping around for these three devices. Viewing from the better than expected results of the overall design, it is obvious that the time spent in search of these devices was well worth it.

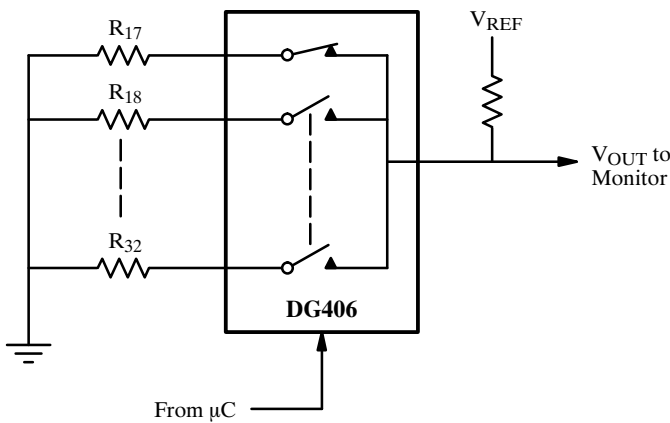

Figure 4. Saturated Oxygen Simulation Circuit

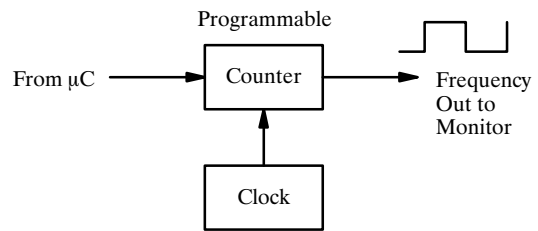

Figure 5. Pulse Rate Simulator